

Detachable tool holder for collaborative robot

Collaborative robots (Cobots) are being used more and more frequently in manufacturing. These robots are designed to perform one specific task, such as pick and place or screwing, at a time. Task-switching is only possible by changing the robot's manipulator manually or via expensive automatic tool changers.

The M.A.N.O. tool holder enables a Cobot to pick up and use tools without assistance, thus allowing to combine multiple tasks to be performed via an automated setup.

TECHNOLOGY

The tool holder enhances the functionality of already existing robots that perform their tasks via a "pick up and place" mechanism, facilitated by a jaw gripper. The tool holder and the tool have to be placed within the arm's reach of the robot, then the robot can autonomously pick it up, use the tool and change it without any manual assistance.

The tool holder has two critical functionalities – first, there is a locking mechanism that is activated when the robot picks up the tool holder and is not released until the robot returns the tool holder to its original position; second, the tool holder activates the tool held inside in order to perform the task. This second functionality couples the movement of the gripper to the activation switch of the tool. The mechanism is entirely mechanical, meaning there is no need for any extra electronics or software.

APPLICATION

The tool holder can be customized for any battery-powered tool, and multiple different tools could be used easily. Tool sharing is even possible between two robots, or with a human, in overlapping workspaces. The holder itself is 3D printed, meaning new designs for new tools could be very quickly produced. Overall, the tool holder enables greater efficiency in manufacturing processes, by enhancing the automation capabilities of Cobots.

ADVANTAGES

- easy tool sharing (robot/robot or robot/human)
- replaces specific manipulators
- entirely mechanic device
- no additional software for tool use required
- 3D printable design
- customizable to any battery powered tool

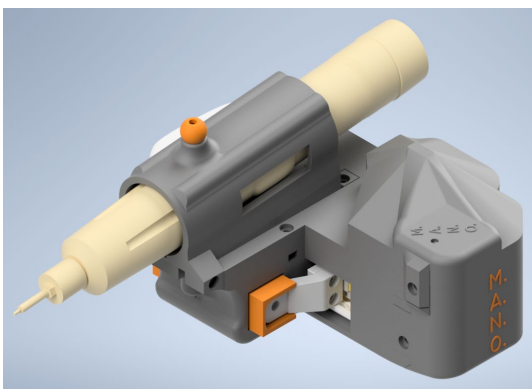

REFERENCE:

M049/2019

APPLICATIONS:

Manufacturing processes with collaborative robots

DEVELOPMENT STATUS:

Functional prototype

KEYWORDS:

Collaborative Robot
Cobot
Tool holding device
Manufacturing
Tool sharing

IPR:

Austrian Patent granted (AT523914);
PCT application filed

OPTIONS:

R&D co-operation
License agreement
Patent sale

INVENTORS:

Marcus Ophoven
Christian Clemenz
Christina Schmidbauer
Sebastian Schlund
Hans Küffner-McCauley

CONTACT:

Karin Hofmann

TU Wien
Research and Transfer
Support

T: +43.1.58801.415241

karin.hofmann@tuwien.ac.at

www.rt.tuwien.ac.at